

TESTING APPLICATION STANDARD (TAS) No. 102-95

⋮

TEST PROCEDURE FOR STATIC UPLIFT RESISTANCE OF MECHANICALLY ATTACHED, RIGID ROOF SYSTEMS [For Mechanically Attached, Rigid Roof Systems Accompanied by a Clip, Refer to TAS 102(A)]

1. Scope

- 1.1 This Protocol covers the determination of: 1) the average weight (W) of a rigid component; 2) the restoring moment due to gravity (M_g) provided by the component's weight; 3) the minimum characteristic resistance load (F'); and, 4) the attachment resistance expressed as a moment (M_f) provided by the mechanical attachment of the component.
- 1.2 The test procedures outlined herein shall be used to determine: 1) the average mass (m) of a rigid component; and, 2) the resistance to an uplift load placed on a mechanically attached rigid component installed on a test specimen which is set at a predetermined test slope (θ).

The point of application of the uplift load shall be dependent upon whether the system has been or is to be tested for wind characteristics in compliance with TAS 108.

Prior to conducting the testing, the system manufacturer shall specify to the testing agency a test slope (θ) of either 9.5° (2 in:12 in.) or 18.5° (4 in:12 in.).

NOTES:

1. The *Florida Building Code, Building* requires a "Counter-Batten" application for nail-on tiles installed on slopes 2 in:12 in. to < 4 in:12 in. See RAS 118.
 2. The *Florida Building Code, Building* requires a "Horizontal Batten" application for nail-on tiles installed on slopes greater than 7 in:12 in. See RAS 119.
- 1.3 The calculations outlined herein shall be used to determine: 1) the average weight (W) of the rigid component; 2) the restoring moment due to gravity (M_g), deter-

mined from knowledge of the component's average weight (W) and dimension, and the test slope (θ); 3) the minimum characteristic resistance load (F') which is representative of the test data noted in Section 1.2; and, 4) the attachment resistance expressed as a moment (M_f) provided by the tile's method of attachment at the test slope (θ).

- 1.4 All testing and calculations shall be conducted by an approved testing agency and all test reports, including calculations, shall be signed by a Registered Design Professional per F.S., Section 471 or 481.
- 1.5 A safety factor of 2:1 shall be applied to test results, as noted in Section 9.4.1.

⋮

2. Referenced Documents

- 2.1 *The Florida Building Code, Building.*
- 2.2 *Application Standards*
 - TAS 108 Test Procedure for Wind Tunnel Testing of Air Permeable, Rigid, Discontinuous Roof Systems
 - RAS 127 Standard Procedure of Determining Applicability of Tile System Installation
- 2.3 *Application Standards*
 - RAS 118 Installation of Mechanically Fastened Roof Tile Systems. System two: Direct Deck and Counter Battens only.
 - RAS 119 Installation of Mechanically Fastened Roof Tile Systems. System one: Direct Deck and Horizontal Battens only.
- 2.4 *The American Plywood Association Performance Standards and Polices for Structural-Use Panels*

- 2.5 *Redland Technologies - New Technology & Product Development Centre*
Fixing Studies for MRTI Normal Weight Tiles - SBCCI Submission
- 2.6 *The American Society of Civil Engineers (ASCE)*
ASCE 7; Minimum Design Loads for Buildings and Other Structures
- 2.7 *ASTM Standards:*
 - E 380 Excerpts from the Standard Practice for Use of the International System of Units (SI) (the Modernized Metric System)
- 2.8 *Roof Consultants Institute*
Glossary of Terms

3. Terminology & Units

- 3.1 Definitions - for definitions of terms in this Protocol, refer to Chapters 2 and 15 (High-Velocity Hurricane Zones) of the *Florida Building Code, Building* and/or Fixing Studies for MRTI Normal Weight Tiles; and/or the RCI Glossary of Terms. The definitions from the *Florida Building Code, Building* shall take precedence.
- 3.2 Units - For conversion of U.S. customary units to SI units, refer to ASTM E 380.

4. Significance and Use

- 4.1 The test procedures and calculations specified herein provide a means for establishing: 1) the average weight (W) of the rigid component; 2) the restoring moment due to gravity (M_g) provided by the component's weight; 3) the minimum characteristic resistance load (F'); and, 4) the attachment resistance expressed as a moment (M_r) provided by the mechanical attachment.

The component's average weight (W) is a measure of its gravitational force of attraction to the earth's surface. Sea level conditions are assumed for the purposes of this Protocol.

The component's restoring moment due to gravity (M_g) is a measure of its ability to resist a rotational force (moment) prior to its attachment to the substrate, when posi-

tioned at the specified test slope (θ). It represents the component's weight in terms of resisting a rotational force.

The minimum characteristic resistance load (F') represents the combined effects of the component's weight and its attachment to the substrate in their ability to resist an uplift load placed at a predetermined location on the component.

The attachment resistance expressed as a moment (M_r) is a measure of the attachment's ability to resist the rotational force incurred upon it due to the uplift load placed on the component.

- 4.2 Systems which are also tested for wind characteristics (henceforth "moment based systems"), in compliance with TAS 108, shall have: 1) the restoring moment due to gravity (M_g); 2) the minimum characteristic resistance load (F'); and, 3) the attachment resistance expressed as a moment (M_r), determined under this Protocol, listed in the system manufacturer's Product Approval for reference. These values are used, in conjunction with the system's aerodynamic multiplier (1), also listed in the Product Approval, in the calculations and procedures outlined in RAS 127 to determine the acceptable method(s) of attachment for system installation on a particular building in the High Velocity Hurricane Zone jurisdiction. While the calculations and procedures set forth in RAS 127 may be conducted by the Uniform Building Permit applicant, where the pressures (P) have been determined based on Table 1 and do not require additional signed and sealed engineering design calculations. All other calculations shall be conducted by a Professional Engineer or Registered Architect.

- 4.3 Systems which are not tested for wind characteristics (henceforth "uplift based systems"), due to size constraints, air impermeability, or manufacturer decision, shall have: 1) the component's average weight (W); and, 2) the minimum characteristic resistance load (F') listed in the system manufacturer's Product Approval for reference. These values are used in the calculations and procedures outlined in RAS 127 to determine the ac-

ceptable method(s) of attachment for system installation on a particular building in the High-Velocity Hurricane Zone jurisdiction. While the calculations and procedures set forth in RAS 127 may be conducted by the Uniform Building Permit applicant, where the pressures (P) have been determined based on Table 1 and do not require additional signed and sealed engineering design calculations. All other calculations shall be conducted by a Professional Engineer or Registered Architect.

NOTE: Uplift based systems need only be tested for average weight (W) and minimum characteristic resistance load (F') in this Protocol.

4.4 Testing in compliance with this Protocol and subsequent listing of the results in the system manufacturer's Product Approval, as noted in Sections 4.2 or 4.3, does not imply automatic approval for installation of the tested system on any building in the High-Velocity Hurricane Zone jurisdiction. The applicability of system installation shall be determined in one of the following two ways:

4.4.1 For exposure "C" buildings having a roof mean height less than or equal to 40 feet, the Uniform Building Permit applicant may utilize the procedures set forth in RAS 127 to determine acceptable methods of attachment. The procedure outlined in Section 4.4.2 is also an option for those exposure "C" buildings having a roof mean height less than or equal to 40 feet.

4.4.2 The Authority Having Jurisdiction shall determine the acceptability of system installation based on results from engineering design calculations in compliance with RAS 127. These calculations shall be: 1) performed for all buildings having a roof mean height greater than 40 feet; 2) performed, signed and sealed by a Registered Design Professional per F.S., Section 471 or 481; and, 3) shall take precedence over the procedures outlined in Section 4.4.1.

5. Apparatus

5.1 The test apparatus shall consist of a steel framework and loading bar constructed of sufficient strength to remain rigid when loads of up to 250 lbf are applied. The frame shall be fixed to a solid floor so as to prevent movement and provide a solid reference level for deflection measurements. (See Figure 1, attached.)

5.2 The loading bar position shall be adjustable along the frame width to facilitate the upward loading of the "test component." The opposite end of the loading bar shall be attached to a hydraulic jack, or other similarly controllable mechanical device. (See Figure 1, attached.)

5.3 Component Load Transfer (See Figure 1, attached)

5.3.1 Moment based systems shall have the static uplift load applied at a point along the center of the component, $0.76 \times l$ (l = component length) from the head of the component.

5.3.2 Uplift based systems shall have the static uplift load applied at the center of the component.

5.3.3 Prior to test specimen construction, install one of the following load transfer devices to the "test component" at the appropriate location, as noted in Section 5.3.1 or 5.3.2, above.

- Drill a hole at the appropriate location in the "test component" using a 0.203 in. - 0.205 in. nonpercussion, cutting carbide bit to minimize spalling. Discard any component which, subsequent to drilling, exhibits spalling in excess of 1/4 in. Install a 1/4 in. diameter, threaded concrete anchor through the pre-drilled hole allowing for penetration not greater than 1/4 in.
- Drill a hole at the appropriate location in the "test component" using a 7/16 in. - 1/4 in. non-percussion, cutting car-

bide bit to minimize spalling. Discard any component which, subsequent to drilling, exhibits spalling in excess of $\frac{1}{4}$ in. Cover the bottom of the pre-drilled hole with duct tape and fill the hole with epoxy. Insert a $\frac{3}{8}$ in. diameter epoxy bolt into the hole and allow to cure for 24 hours prior to component installation.

- 5.4 A load cell, attached to or forming part of the loading bar, shall be rigidly attached to the load transfer device, noted in Section 5.3.3, to measure the load applied. The load cell shall have a digital, dial or chart recorded output capable of recording loads up to 250 lbf and a resolution of 0.5%. The load cell shall be capable of recording the ultimate load incurred upon the “test component.” (See Figure 1, attached.)
- 5.5 Linear displacement gauges (i.e., dial gauges) shall be used to record the “test component” and/or fastener displacement. Gauges shall be firmly fixed to the plywood substrate adjacent to the “test component.” (See Figure 1, attached.)
- 5.6 A measurement device with an accuracy of 0.05 lbf shall be used to determine the average mass of the “test components.”

6. Test Limitations and Precautions

- 6.1 During the test, all testing agency representatives and other test observers shall wear eye protection to prevent injury.
- 6.2 The Protocol may involve hazardous materials, operations and equipment. This Protocol does not purport to address all of the safety problems associated with its use. It is the responsibility of the user to consult and establish appropriate safety and health practices and determine the applicability of regulatory limitations prior to use.
- 6.3 Care must be taken not to damage, twist or distort the test specimen during handling as this may affect the test specimen’s performance.

- 7. **Test Specimen** - 14 test specimens shall be constructed in compliance with the specification herein. **Prior to test specimen construction, refer to Section 8.1 herein.**

7.1 Deck

- 7.1.1 The wood test deck shall consist of APA 32/16 span rated sheathing of $\frac{15}{32}$ in. thickness installed over 2 in. x 6 in. perimeter supports and 2 in. x 6 in. intermediate supports spaced 24 in. apart. The sheathing shall be attached with 8d common nails at 6 in. o.c. at panel edges and 12 in. o.c. at intermediate supports. The sheathing shall be sized to accommodate the component installation specified in Section 7.6 while meeting the size constraints of the steel test frame. The test deck shall be capable of resisting a minimum dead load of 55 psf.

7.2 Underlayment

- 7.2.1 Underlayment shall be a standard 30/90 system with a 30 lb ASTM D 226, type II anchor sheet and an ASTM D 6380 CLASS M mineral surface roll roofing as the top ply.
- 7.2.2 The anchor sheet shall be mechanically attached to the wood sheathing, with 12 ga. roofing nails and $1\frac{5}{8}$ in. tin caps, in a 12 in. grid pattern staggered in two rows in the field and 6 in. o.c. attachment at any laps. The mineral surface top ply shall be applied in a full mopping of ASTM D 312, type IV asphalt.

7.3 Fasteners

- 7.3.1 Component attachment fasteners (i.e. nails, screws, tile straps, etc.) shall be those recommended in the system manufacturer’s published installation instructions. Nails shall be not less than 0.109 in. in diameter and minimum screws shall be #8 diameter screw fasteners. Component attachment fasteners shall meet the corrosion requirements set forth in TAS 114, Appendix E.

7.4 Battens (if applicable)

7.4.1 Horizontal Batten System

- Horizontal battens shall be of nominal 1 in. x 2 in. dimensional lumber and shall be spaced to provide a minimum 3 in. head lap, or to match the interlocking configuration of the component's profile.
- Horizontal battens shall be nailed to the wood test deck at 6 in. o.c. using 12 ga. roofing nails.

7.4.2 Counter Batten System

- Vertical battens shall be of nominal 1 in. x 4 in. lumber and shall be spaced 24 in. over the intermediate supports (trusses).
- Vertical battens shall be nailed to the wood test deck at 6 in. o.c. using 12 ga. roofing nails.
- Horizontal battens (counter battens) shall be as noted in Section 7.4.1, nailed to the 1 in. x 4 in. vertical battens using 12 ga. roofing nails of sufficient length to penetrate both battens.

7.5 Supplemental Adhesive (Optional)

7.5.1 The applicant may use a "dab" of adhesive applied to the underside of each "test tile" for additional component securement. The adhesive shall have a Roofing Component Product Approval for use with tile systems.

7.5.2 The tile adhesive shall be applied at the "test tile" headlap in a single 3/8 in. wide x 1 1/4 in. long bead placed between 1 1/2 in. and 2 in. from the nose of the "test tile."

7.6 Rigid Components

7.6.1 The type of mechanically attached, rigid roof system shall be identified and the system's rigid components shall have an identifi-

able mark, confirming the system manufacturer.

7.6.2 Each component shall be installed in compliance with the system manufacturer's published installation instructions; the current Product Approval; and/or the minimum requirements set forth in Chapter 15 (High-Velocity Hurricane Zones) of the *Florida Building Code, Building*. The requirements of the *Florida Building Code, Building* shall take precedence.

7.6.3 The first course shall consist of two components installed at the lower edge of the test deck, either directly to the deck or over battens. The second course shall consist of the "test component" installed over the first course, either directly to the deck or over battens, insuring for a minimum 3 in. head lap. Components in the first course, which are not tested, shall be installed to insure the "test component," in the second course, is at the correct angle relative to the sheathing. (See Figure 1, attached.)

7.7 During test specimen construction, measure and record the "test component angle" (α); the angle between the bottom surface of the "test component" and the substrate. Record this angle for each of the 14 test specimens and determine an average "test component angle."

7.8 The test specimen shall be inspected by a Registered Design Professional per F.S., Section 471 or 481 or Registered Roof Consultant who shall certify, in the final test report, that it was constructed in compliance with the provisions of this Protocol.

8. Procedure

8.1 Prior to installing the "test components" on the test specimens, determine the mass of the 14 "test components" to an accuracy of 0.05 lbm, tabulate the data and determine the average mass.

- 8.2 Mount one of the 14 test specimens on the test apparatus at the predetermined test slope (θ), as noted in Section 1.2.
- 8.3 Position the displacement devices to measure displacement in the direction of the applied load. Position one device at the nose of the “test component.” For “S” shaped clay or concrete tile, position an additional device at the fastener point in the valley of the “test tile.”
- 8.4 Connect the loading and load measurement devices rigidly to the load transfer device, noted in Section 5.3.3, and apply an uplift load. Care shall be taken to ensure that the uplift load is applied vertically and that the “test component’s” displacement rate does not exceed 2 in. per minute.
- 8.5 An observer shall monitor the component, its attachment point(s) and the displacement gauge(s) while a second observer monitors the load measuring device. Record the ultimate load at which: 1) the “test component” or fastener breaks or cracks; 2) the nose of the “test component” vertically displaces 2 in.; or 3) for “S” shaped clay or concrete tile only, the fastener displaces vertically $1/4$ in.
- 8.6 Repeat Sections 8.2 through 8.5 for each of the remaining test specimens and tabulate the ultimate uplift loads.

9. Calculations

9.1 Weight (W)

- 9.1.1 Determine the average weight of the 14 “test components” using the average mass of these components, determined in Section 8.1, and the following equation.

$$W = m \times \frac{1 \text{ slug}}{32.174 \text{ lbf}} \times g \quad \text{where,}$$

W = average component weight (lbf);

m = average component mass (lbm); and,

g = 32.2 ft/s^2 = acceleration of gravity constant.

NOTE: $1 \text{ slug} = 1 \text{ lbf s}^2/\text{ft}$

9.2 Restoring Moment due to Gravity (M_g)

NOTE: This calculation need only be performed for moment based systems.

- 9.2.1 Determine the restoring moment due to gravity (M_g) at the test slope (θ) using the component’s average weight (W), determined in Section 9.1, the “test component angle” (α), determined in Section 7.7, and the following equation.

$$M_g = W \times \cos(\theta - \alpha) \times L_g$$

where,

M_g = restoring moment due to gravity (ft-lbf);

W = component’s average weight (lbf);

L_g = component’s gravitational moment arm (ft);

θ = test slope (degrees); and,

α = “test component angle” (degrees)

NOTES:

1. The component’s gravitational moment arm (L_g) is the orthogonal distance from the component’s center of gravity to its axis of rotation.
2. For “S” shaped clay or concrete tile, the axis of rotation is located toward the upper left corner of the tile. For such tile attached directly to the deck, a gravitational moment arm of $L_g = 0.728$ feet has been found to be typical. For such tile attached through battens, a gravitational moment arm of $L_g = 0.679$ feet has been found to be typical. The testing agency shall confirm these values through measurement prior to use in the above noted equation.

3. For all other components attached directly to the deck:

$$L_g = (0.5 \times l) \text{ where,}$$

l = component length.

4. For all other components attached through battens:

$$L_g = (0.5 \times l) - y \text{ where,}$$

l = component length;
and,

y = distance from head of component to center line of horizontal batten.

$$F' = \left(\frac{\bar{F} - W}{MS} \right) \quad \text{where,}$$

F' = minimum characteristic resistance load;

\bar{F} = mean ultimate load;

MS = margin of safety = 2; and,

W = average weight.

NOTE: The requirement noted in Section 9.3.3.1 shall be met prior to determining the minimum characteristic resistance load (F').

9.3 Statistical Analysis of Test Data

9.3.1 From the 14 recorded ultimate loads, eliminate the “high” and “low” values leaving 12 ultimate load values for statistical analysis.

9.3.2 Determine the mean ultimate load (F) and the standard deviation (S_F) using the tabulated data from Section 8 and the following equations.

$$\bar{F} = \frac{1}{12} \sum_{i=1}^{12} F_i \quad \text{and,}$$

$$S_F = \sqrt{\frac{1}{11} \sum_{i=1}^{12} (F_i - \bar{F})^2}$$

\bar{F} = average ultimate load (lbf);

S_F = standard deviation;

F = recorded ultimate load; and,

i = 1, 2, 3, . . . , 12 = test number.

9.3.3 Determine the percent deviation from the mean (S'_F) using information from Section 9.3.2 and the following equation.

$$S'_F = \left(\frac{S_F}{F} \right) \times 100 \quad \text{where,}$$

S'_F = percent deviation from the mean (%);

S_F = standard deviation; and,

F = mean ultimate load.

9.3.3.1 If the percent deviation from the mean (S'_F) is greater than or equal to 20%, then the test results shall be considered null and void and the test shall be considered a re-test.

9.4 Minimum Characteristic Resistance Load (F')

9.4.1 Determine the minimum characteristic resistance load (F') using the mean ultimate load (F) and the following equation.

9.5 Attachment Resistance Expressed as a Moment (M_f)

NOTE: This calculation need only be performed for moment based systems.

9.5.1 Determine the attachment resistance expressed as a moment (M_f) provided by the component’s attachment at test slope (q) using the minimum characteristic resistance load (F'), determined in Section 9.4.1, the “test tile angle” (α), determined in Section 7.7, and the following equation.

$$M_f = [F' \times \cos(\theta - \alpha) \times L_r] \quad \text{where,}$$

M_f = attachment resistance (ft-lbf);

F' = minimum characteristic resistance load (lbf);

L_r = tile’s attachment moment arm (ft);

θ = test slope (degrees); and,

α = test tile angle (degrees).

NOTES:

1. The component’s attachment moment arm (L_r) is the orthogonal distance from the point of load application to its axis of rotation.
2. Components Other Than “S” Shaped Clay or Concrete Tile:

Direct deck:

$$L_r = (0.76 \times l) \quad \text{where,}$$

l = component length.

Over battens:

$L_r = (0.76 \times l) - y$ where,

l = component length;
and,

y = distance from head of component to center-line of horizontal batten

- 3. "S" Shaped Clay or Concrete Tile: For 'S' shaped clay or concrete tile, the axis of rotation is located toward the upper left corner of the tile. For this reason the tile's attachment moment arm (L_r) shall be measured for the tile in question, either installed directly to the deck or over battens. Measure the orthogonal distance from the point of load application (as noted in Section 5.3.1) to the axis of rotation. This distance is the tile's attachment moment arm (L_r).

specimens and an average "test component angle."

- 10.1.6 Tabulated ultimate load measurements ($F_1, F_2, F_3, \dots F_{12}$) for the 14 test specimens.
- 10.1.7 Average component weight (W) calculations and results.
- 10.1.8 Restoring moment due to gravity (M_g) calculations and results (needed only for moment based systems).
- 10.1.9 Calculations and results confirming the percent deviation from the mean (S'_F) less than 20%.
- 10.1.10 Minimum characteristic resistance load (F') calculations and results.
- 10.1.11 Attachment resistance expressed as a moment (M_g) calculations and results (needed only for moment based systems).
- 10.1.12 A video tape of all pertinent aspects of the test, including test specimen construction and up-lift load applications.

10. Report

- 10.1 The final test report shall include the following:
 - 10.1.1 A description and sketch of the rigid component designed for use in the mechanically attached, rigid roof system, including the manufacturer and type of component.
 - 10.1.2 A statement of which load transfer device, noted in Section 5.3, was utilized and which test slope (θ) was selected by the manufacturer.
 - 10.1.3 A detailed report of the method of test specimen construction, including a photograph of the test specimen and certification by a Registered Design Professional per F.S., Section 471 or 481 or Registered Roof Consultant that the test specimen was constructed in compliance with the specifications of the Protocol.
 - 10.1.4 Tabulated results of mass measurements of the 14 "test components" and an average mass.
 - 10.1.5 Tabulated "test component angle" (α) measurements for the 14 test

⋮

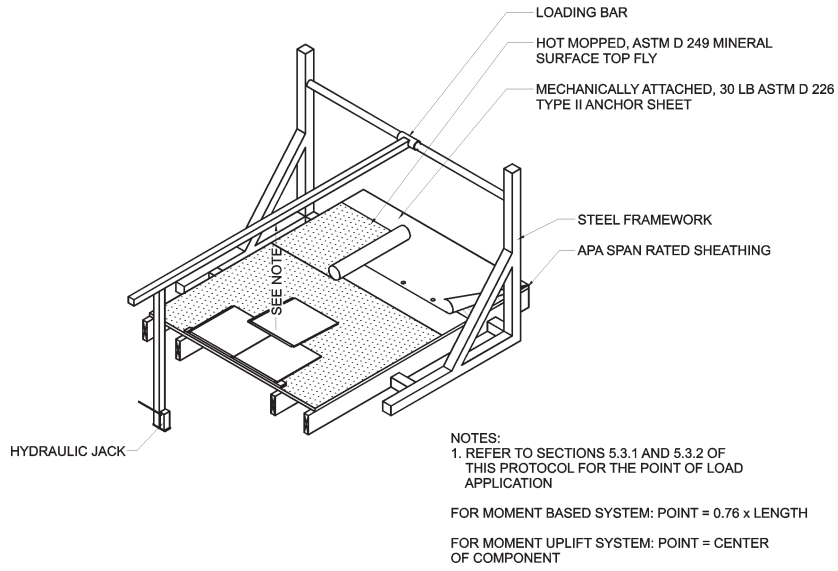

FIGURE 1
STATIC UPLIFT TEST APPARATUS

